



QUANTUM[®]

Total Ankle System

OrthoPlanify™

Patient Specific Instrumentation

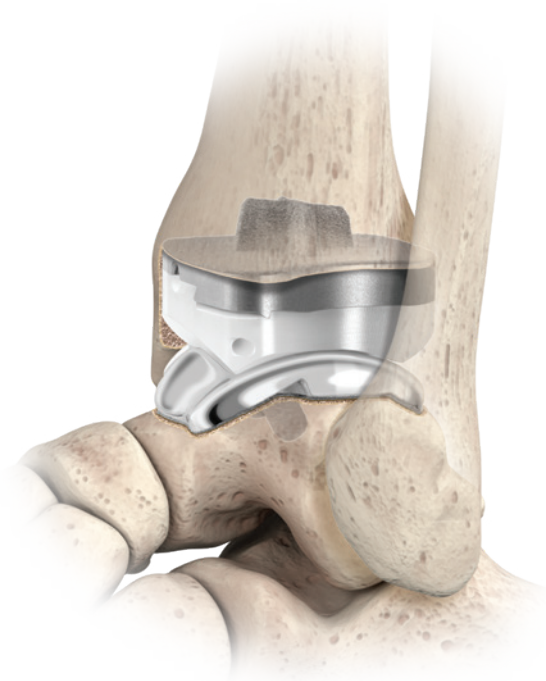

Table of Contents

■ System Introduction	3
■ Standard Talar Technique with PSI	
Initial Tibial Preparation.....	4
Initial Talar Preparation	7
Resection Verification and Option Recut.....	9
Final Talar Preparation	10
Trialing	11
Tibial Stem Preparation	12
Implantation	13
■ Flat-Cut Talar Technique with PSI	
Initial Tibial Preparation.....	15
Initial Talar Preparation	18
Resection Verification and Option Recut.....	20
Final Talar Preparation	21
Trialing	22
Tibial Stem Preparation	23
Implantation	23
Instrumentation	25
General Information	26
Indications / Contraindications	27
Ordering Information	28

System Introduction



The QUANTUM® Total Ankle System is designed to address the complexity of TAR and allow reproducible outcomes for every surgeon.

Simplified Patient Specific Tools:

- OrthoPlanify platform designed to provide complete visualization during case planning
- Web-based portal for easy surgeon access
- Reconstruction and planning using CT scan and weight-bearing X-rays
- 3D printed, custom tibial and talar cutting and drilling guides
- Surgeon has full control of implant placement prior to case validation

Implants Designed to Increase Longevity:

- Favorable gravimetric wear rate compared to competitive systems*

Intuitive Instrumentation:

- Two single-level trays for case execution
- Streamlined procedure and tray design intended to reduce the dependency on specialists

Tibial Components:

- Curved medial profile **1** and lateral fibular contour **2**
- Cross-shaped keel for rotational stability and direct axial loading
- Side-specific, Standard and Long versions, in sizes 2 through 6, to cater to patient anatomy
- Designed to rest on the cortical rim
- Titanium alloy with titanium porous coating

SIZE X or X+1

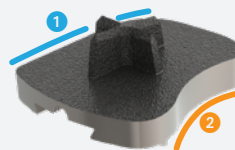

Standard Tibial Implant

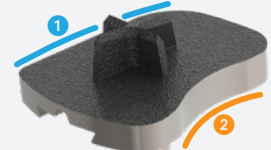

Long Tibial Implant

Tibial Inserts:

- Side-specific implants for sizes 2 through 6, in 8 thicknesses (5-15mm)
- Dovetail locking feature
- Vacuum sealed and gamma sterilized
- Ultra-high molecular weight polyethylene

SIZE X

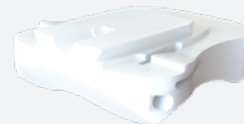

Tibial Insert

Talar Components:

- Side-specific, Standard and Flat-Cut varieties, in sizes 2 through 6
- Double radius of curvature, and tronconic shape, designed to replicate healthy ankle kinematics
- CoCr with titanium porous coating

SIZE X

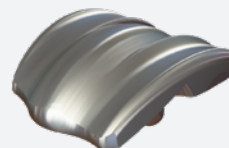

Standard Talar Implant

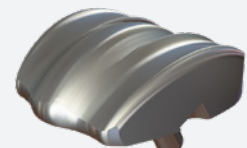

Flat-Cut Talar Implant



*Data on file

Standard Talar Technique with PSI

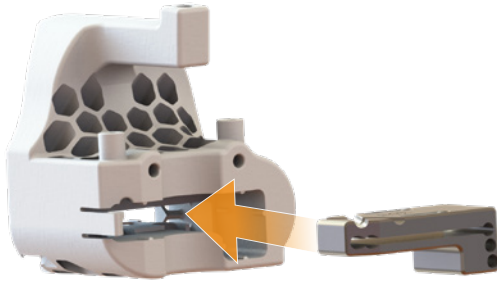

Figure 1. Tibial PSI and Resection Guide

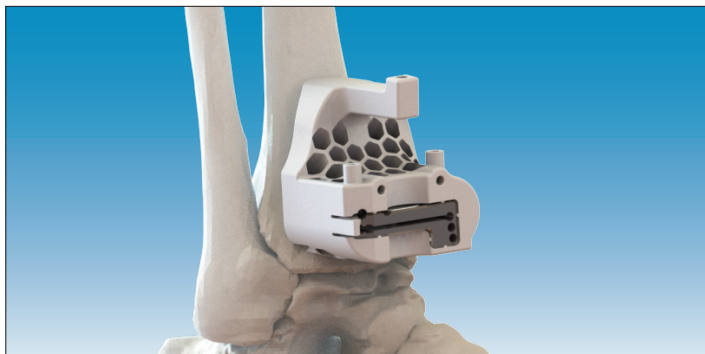

Figure 2. Placement of Tibial PSI Guide

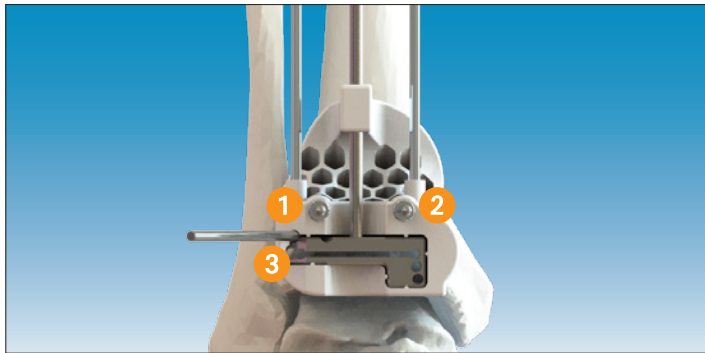

Figure 3. K-wire Fixation of Tibial PSI Guide

1. Initial Tibial Preparation

Assembly of Tibial Resection Guide to Tibial PSI Guide

Once the sterile field is established, select the appropriate Resection Guide for Tibial PSI from the instrument set, as indicated by the planning report and etching on the Tibial PSI Guide.

There are three Resection Guides for Tibial PSI which may be used for either left or right cases:

- A12 for size 2
- A34 for sizes 3 and 4
- A56 for sizes 5 and 6

Assemble the selected Resection Guide for Tibial PSI to the Tibial PSI Guide by sliding it into the dedicated slot on the anterior aspect of the guide (**Figure 1**).

Placement of the Tibial PSI Guide

Remove all remaining cartilage which may inhibit placement of the Tibial PSI Guide onto the anterior tibia.

! Note: Any osteophytes identified during the planning process should remain intact in order to increase PSI stability. Refer to the associated planning report for clarification of these landmarks on a case-by-case basis.

Place the Tibial PSI Guide onto the tibia and seat it in the appropriate position on the patient's anatomy based on the surgical plan (**Figure 2**).

Full contact of the Tibial PSI Guide with the tibia must be observed before proceeding to the next step.

! Tip: Placement of the Tibial PSI Guide onto the Tibial Bone Model may help to provide guidance for the appropriate tactile feedback upon proper seating to the bone.

Tibial PSI Guide Fixation

Once the Tibial PSI Guide is in position, use two parallel 2.5mm Olive Wires **1** **2** and a single oblique 2.5mm K-wire **3** to temporarily fix the guide to the tibia and prevent any backward movement during the cutting process (**Figure 3**).

! Note: When inserting the Olive Wires or K-Wires through the Tibial PSI Guide, take care to apply constant pressure over the guide in order to maintain bone contact and avoid unintentional movement of the guide.

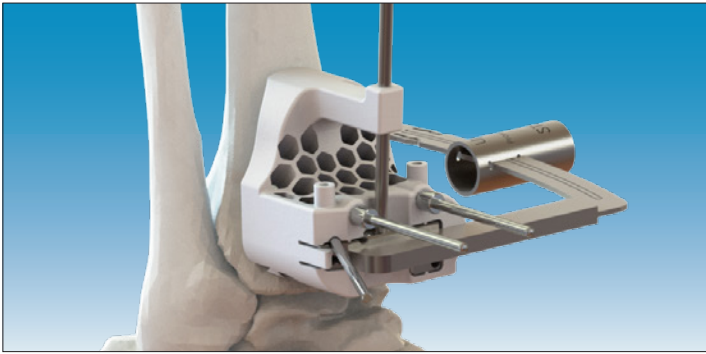

Figure 4. Assembly of Visualization Bow



Figure 5. Tibial Cut Trajectory and Nominal Resection

Insert the Tibial Axis through the central proximal hole of the Tibial PSI Guide and seat into the Resect Guide. Confirm proper positioning relative to the tibial mechanical axis using fluoroscopy. If necessary, remove the Olive Wires and K-wire to enable repositioning of the Tibial PSI Guide prior to moving to the next step.

! Note: The Tibial Axis must be fully seated into the Resection Guide to achieve stability and proper alignment with the Tibial PSI Guide.

Two vertical 2.5mm K-Wires may be placed into the superomedial and superolateral holes of the guide to confirm the mediolateral positioning of the Tibial PSI Guide.

Tibial Cut Visualization

Assemble the Control Cylinder for Standard Cut onto the Visualization Bow by sliding the end of the bow through the slot on the side of the cylinder with the “Up” inscription oriented proximally.

! Note: The Visualization Bow may be positioned medially or laterally based on surgeon preference and accessibility. Take care to ensure proper orientation of the Control Cylinder before moving to the next step.

Insert the Visualization Bow into the cutting slot of the Resection Guide until fully seated against the anterior aspect of the guide (**Figure 4**).

Confirm placement with fluoroscopic verification.

The Visualization Bow corresponds with the cut trajectory achieved through the Tibial PSI Guide while the distance from the bow to the distal aspect of the Control Cylinder for Standard Cut represents the 9mm nominal cut height.

! Tip: Take care to check for proper alignment of the fluoroscopy arm during this step by confirming that the cylinder is a perfect circle on the lateral view (**Figure 5**).

! Note: The 9mm nominal tibial resection can be modified during the planning process. If the tibial resection thickness was modified from nominal, the Control Cylinder may only be used as an alignment tool. The Visualization Bow will be used to verify the cut trajectory and tibial slope.

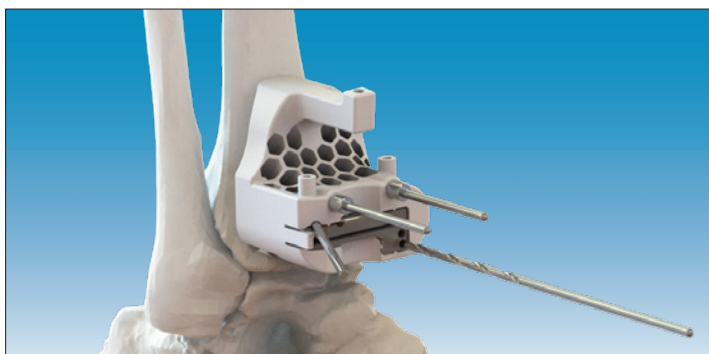

Figure 6. Tibial Stamping



Figure 7. K-Wire Insertion



Figure 8. Tibial Resection

Tibial Stamping

The vertical tibial cut is created in a stamping fashion with the use of a 2.5mm drill.

Using a wire driver, insert and remove the 2.5mm drill through each hole in the Resection Guide starting with the most distal and proceeding proximally in sequence (**Figure 6**).

Once the vertical tibial cut is completed, insert 2.5mm K-wires into the medial and lateral boundaries of the cutting slot of the Resection Guide (**Figure 7**).

! Note: There are two lateral holes located on each Resection Guide. The more lateral hole corresponds to the larger size (i.e. the more lateral hole on the A34 Guide is used when a Size 4 Tibial Implant was planned).

Horizontal Tibial Cut

Complete the horizontal tibial cut through the captured cutting slot in the Resection Guide (**Figure 8**).

! Note: Saw blades are not provided with the system. A narrow graduated saw blade that is 1.27mm thick, 13mm wide, and at least 80mm long is recommended for use.

! Tip: In order to avoid displacement of the Tibial PSI Guide, insert the sawblade into the center of the Resection Guide cutting slot and initiate the saw motion just prior to contacting the bone.

Remove the Olive Wires, K-Wires, and the Tibial PSI Guide once the tibial resection is complete.

If necessary, complete the tibial resection by hand. Use caution to follow the cut trajectory in order to maintain the planned orientation.

Remove all resected bone.

! Tip: The Corner Chisel may be used to aid in connection of the vertical and horizontal tibial resections for bone removal.

! Note: The talar dome will prevent full removal of the tibial bone resections at this point. Take care to remove the anterior half of the tibial resection to allow for seating of the Talar PSI Guide in the next step.

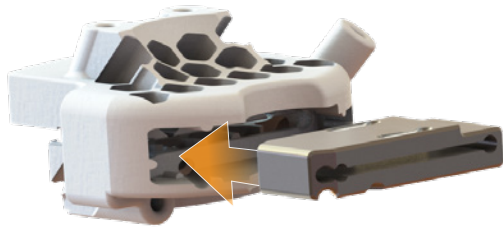

Figure 9. Standard Talar PSI and Resection Guide



Figure 10. Placement of Standard Talar PSI Guide



Figure 11. K-Wire Fixation of Standard Talar PSI Guide

2. Initial Talar Preparation

Assembly of Talar Resection Guide to Standard Talar PSI Guide

Following the planning report and etching on the Standard Talar PSI Guide, select the appropriate Resection Guide for Talar PSI from the instrument set.

There are three Resection Guides for Talar PSI which may be used for either left or right cases:

- B12 for size 2
- B34 for sizes 3 and 4
- B56 for sizes 5 and 6

Assemble the selected Resection Guide for Talar PSI to the Standard Talar PSI Guide by sliding it into the dedicated slot on the anterior aspect of the guide (**Figure 9**).

Positioning of the Standard Talar PSI Guide

Remove all remaining cartilage which may inhibit placement of the Talar PSI Guide onto the talus.

! *Note:* Any osteophytes identified during the planning process should remain intact in order to increase PSI stability. Refer to the associated planning report for clarification of these landmarks on a case-by-case basis.

Place the Standard Talar PSI Guide onto the talus and seat it in the appropriate position on the patient's anatomy based on the surgical plan (**Figure 10**).

Full contact of the Standard Talar PSI Guide with the talus must be observed before proceeding to the next step.

! *Tip:* Placement of the Standard Talar PSI Guide onto the Talar Bone Model may help to provide guidance for the appropriate tactile feedback upon proper seating to the bone.

Standard Talar PSI Guide Fixation

Once the Standard Talar PSI Guide is in position, insert two 2.5mm Olive Wires **1** **2** and a single oblique 2.5mm K-wire **3** to temporarily fix the guide to the talus and prevent any backward movement during the cutting process (**Figure 11**).

Note: When inserting the Olive Wires or K-Wires through the Standard Talar PSI Guide, take care to apply constant pressure over the guide in order to maintain bone contact and avoid unintentional movement of the guide.



Figure 12. Assembly of Visualization Bow



Figure 13. Talar Cut Trajectory and Nominal Resection



Figure 14. Marking of Talar Pegs



Figure 15. K-Wire Insertion

Talar Cut Visualization

Assemble the Control Cylinder for Standard Cut onto the Visualization Bow by sliding the end of the bow through the slot on the side of the cylinder with the “Up” inscription oriented proximally.

! *Note:* The Visualization Bow may be positioned medially or laterally based on surgeon preference and accessibility. Take care to ensure proper orientation of the Control Cylinder before moving to the next step.

Insert the Visualization Bow into the cutting slot of the Resection Guide until fully seated against the anterior aspect of the guide (**Figure 12**).

Confirm placement with fluoroscopic verification.

The Visualization Bow corresponds with the cut trajectory achieved through the Standard Talar PSI Guide while the distance from the bow to the proximal aspect of the Control Cylinder for Standard Cut represents the 6mm nominal cut height.

! *Tip:* Take care to check for proper alignment of the fluoroscopy arm during this step by confirming that the cylinder is a perfect circle on the lateral view (**Figure 13**).

! *Note:* The 6mm nominal talar resection can be modified during the planning process. If the talar resection thickness was modified from nominal, the Control Cylinder may only be used as an alignment tool. The Visualization Bow will be used to verify the cut trajectory.

Marking of Talar Pegs

The two posterior-distally angled holes **1** **2** on the proximal aspect of the Standard Talar PSI Guide are used to mark the locations of the talar pegs.

Mark the positions of both pegs by inserting a 2.5mm K-wire into each of the holes. Stop when the K-wire contacts cortical bone on the opposite side to avoid penetration of the subtalar joint (**Figure 14**). Remove both K-wires.

Horizontal Talar Cut

Insert 2.5mm K-wires into the medial and lateral boundaries of the cutting slot of the Resection Guide (**Figure 15**).

! *Note:* There are two lateral holes located on each Resection Guide. The more lateral hole corresponds to the larger size (i.e. the more lateral hole on the B34 Guide is used when a Size 4 Talar Implant was planned).



Figure 16. Talar Resection



Figure 17. Gap Check for Standard Talus

Complete the horizontal talar resection through the captured cutting slot in the Resection Guide (**Figure 16**).

! Note: Saw blades are not provided with the system. A narrow graduated saw blade that is 1.27mm thick, 13mm wide, and at least 80mm long is recommended for use.

! Tip: In order to avoid displacement of the Standard Talar PSI Guide, insert the sawblade into the center of the Resection Guide cutting slot and initiate the saw motion just prior to contacting the bone.

Remove the Olive Wires, K-Wires, and the Standard Talar PSI Guide once the talar resection is complete.

If necessary, complete the talar resection by hand. Use caution to follow the cut trajectory in order to maintain the planned orientation.

Remove the resected talar bone, and residual resected tibial bone, taking care to clear all debris from the area. The Hockey Stick may be used to access and remove any posterior bone fragments.

3. Resection Verification and Option Recut

Insert the Gap Sizer into the prepared joint with the laser marking reading “STD” facing the resected bone surface (**Figure 17**).

! Note: The Gap Sizer is used for Standard and Flat-Cut operations. When the laser marking reading “STD” faces the resected bone surface, the minimum construct thickness with the Standard Talus is simulated.

The Alignment Rod may be inserted into the holes on the handle of the Gap Sizer to allow for lateral fluoroscopic verification of perpendicularity of the tibial and talar resections to the tibial mechanical axis.

If the Gap Sizer indicates that the existing resections will not accommodate the minimum construct thickness, the Resection Cut Adjustment Block shall be used.

! Note: The Resection Cut Adjustment Block may be used for tibial and talar recuts, as indicated by the block’s markings. Ensure the block is oriented correctly depending on the bone being addressed.



Figure 18. Tibial Recut Block



Figure 19. Optional Alignment with Standard Talar Template



Figure 20. Optional Peg Marking with Standard Talar Template



Figure 21. Alignment of Talar Chamfer Resection Guide



Figure 22. K-Wire Fixation of Talar Chamfer Resection Guide

To recut the tibia, insert two 2.5mm K-wires into the holes created by the Olive Wires in the anterior tibia. Take care to orient the Resection Cut Adjustment Block so that the side marked “Tibia” is facing anteriorly and slide the block over the two K-wires at the desired recut height (**Figure 18**).

Insert two 2.5mm K-wires into the medial and lateral cutting slot holes. Then, utilize the previously used saw blade to perform the cut.

Remove the K-wires and Resection Cut Adjustment Block once the recut is complete.

4. Final Talar Preparation

Optional Standard Talar Component Positioning

Should it be desired to modify the position of the talar component versus what was planned with the PSI, place the Standard Talar Template that corresponds to the planned implant size onto the resected talar surface. Initially orient the handle of the Template with the 2nd digit of the operative foot, then refine the rotation as needed to allow for alignment of the talar flanges with the handle (**Figure 19**).

Confirm placement with fluoroscopic verification, with a direct lateral view indicated by a perfect circle view of the thru-hole on the side of the Template.

Full contact between the Template and the talar resection should be obtained prior to moving to the next step.

Fix the Standard Talar Template to the talus using two 2.5mm K-wires. Stop when the K-wires contact cortical bone on the distal side of the talus to avoid penetration of the subtalar joint (**Figure 20**).

Verify placement under fluoroscopy and remove the Template and K-wires.

Positioning of Talar Chamfer Resection Guide

Align the pegs of the appropriately sized Talar Chamfer Resection Guide with the holes previously prepared in the talus with K-wires (**Figure 21**) and secure it in place with one K-wire through either anterior hole of the guide (**Figure 22**).

! *Tip: Prior to securing the Talar Chamfer Resection Guide, ensure full seating with the use of fluoroscopy. Incomplete seating of the Guide may result in incomplete bone preparation.*



Figure 23. Posterior Chamfer Resection



Figure 24. Anterior Chamfer Reaming



Figure 25. Placement of K-wires and Peg Preparation



Figure 26. Impaction of Standard Talar Trial

Posterior Chamfer Preparation

Complete the posterior chamfer resection through the posterior slot of the Talar Chamfer Resection Guide (**Figure 23**).

! Note: Hold the guide firmly during this step to avoid any unintentional movements of the Talar Chamfer Resection Guide during the cutting process.

Anterior Chamfer Preparation

Using the Talar Reamer, prepare the anterior chamfer by reaming within the holes in the anterior portion of the Talar Chamfer Resection Guide (**Figure 24**).

! Note: Hold the guide firmly during this step to avoid any unintentional movements of the Talar Chamfer Resection Guide during the reaming process.

Remove the Talar Chamfer Resection Guide and the resected bone and clean all bone surfaces of debris.

Talar Pegs Preparation

Insert two 2.5mm K-wires into the holes created through the Talar PSI Guide or the Standard Talar Template.

! Tip: Manual insertion of the K-wires is recommended to ensure proper alignment with the previously prepared holes.

Using the 5mm Standard Cannulated Peg Drill, drill over the K-wires until the Drill's step meets the bone (**Figure 25**).

Remove both K-wires.

5. Trialing

Standard Talar Trial Positioning

Following the planning report, select the appropriate Standard Talar Trial, Implant Holder, and Talar Implant Impactor from the instrument tray.

Align the Standard Talar Trial with the prepared talar peg holes and impact it into place with the Talar Implant Impactor (**Figure 26**).

Confirm placement with fluoroscopic verification.

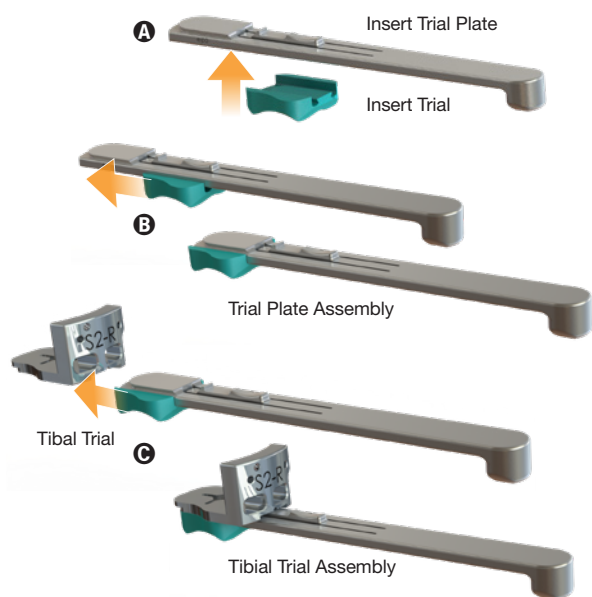

Figure 27. Tibial Trial Assembly

- A** Insert Trial and Trial Plate
- B** Assembly of Insert Trial and Trial Plate
- C** Assembly of Tibial Trial to Trial Plate Sub-Assembly

Tibial Trial Assembly

Following the planning report, select the appropriate Insert Trial Plate and Insert Trial from the instrument tray. Take care to ensure size and side are correct (**Figure 27A**).

Note: The Insert Trial size must be the same size as the selected Talar Implant.

Slide the Insert Trial Plate over the Insert Trial until the two components are clipped together (**Figure 27B**).

Select the appropriate Tibial Trial from the instrument set, taking care to ensure size and side are correct.

Note: The Tibial Implant size must be the same size or one size over the selected Talar Implant.

Slide the Insert Trial Assembly into the Tibial Trial until the two components are clipped together (**Figure 27C**).

Tibial Trial Positioning

Insert the Tibial Trial Assembly into the prepared joint space and trial for fit and laxity. Mobilize the ankle to obtain desired positioning of the assembly over the Standard Talar Trial (**Figure 28**).

If increased construct height or reduced laxity is required, increase the Insert Trial thickness until the construct provides satisfactory results.

Fix the Tibial Trial Assembly to the tibia using two parallel and one oblique 2.5mm K-Wires (**Figure 29**).

6. Tibial Stem Preparation

Remove the Insert Trial and Insert Trial Plate from the Tibial Trial Assembly, leaving the Tibial Trial implant in place on the tibia. Then, remove the Standard Talar Trial from the talus.



Figure 28. Alignment of Tibial Trial Assembly



Figure 29. K-wire Fixation of Tibial Trial Assembly

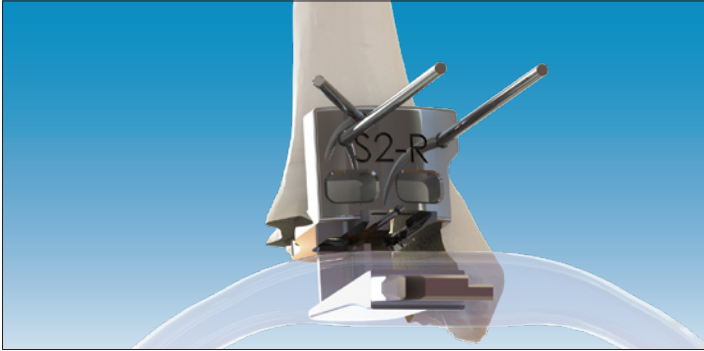

Figure 30. Alignment of Tibial Stem Shaper



Figure 31. Impaction of Tibial Stem Shaper



Figure 32. Assembly of Impaction Tip



Figure 33. Implanted Tibial Component

Thread the Handle into the Impaction Frame until in full contact with the Frame. Then, assemble the Tibial Stem Shaper to the Impaction Frame. Slide the assembly into the prepared joint space while aligning the shaper with the Tibial Trial's cross-shaped socket (**Figure 30**).

Prepare the tibial stem by striking the Impaction Frame Hitting Plate with an axial force to drive the Tibial Stem Shaper into the tibia until complete contact with the Tibial Trial is obtained (**Figure 31**).

Remove the Impaction Frame and the Tibial Stem Shaper.

Remove the oblique K-wire from the tibia and slide the Tibial Trial out of the joint space while leaving the two parallel K-wires in place.

7. Implantation

Final Tibial Implant Insertion

Obtain the appropriate Final Tibial Implant and assemble it to the Tibial Implant Holder.

Assemble the Tibial Implant Guide to the Tibial Implant Holder. Verify the Tibial Implant Guide's correct orientation by referencing the side-specific laser markings on the Guide.

Slide the Tibial Implant Guide Assembly over the parallel K-wires until complete contact with the anterior wall of the tibia is achieved.

Assemble the Impactor Tip to the Impaction Frame. Then, slide the Impactor Tip into the groove on the Tibial Implant Holder until it is nested with the impaction socket on the handle (**Figure 32**).

Strike the Impaction Frame Hitting Plate with an axial force to insert the Tibial Implant into the tibia until fully seated.

⚠ Note: Take care to verify complete insertion of the Tibial Implant and full contact between the Tibial Tray and the tibia (**Figure 33**).

Remove all instrumentation and K-wires from the tibia while leaving the Tibial Implant in place.



Figure 34. Inserted Articular Surface Protector



Figure 35. Standard Talar Implant Insertion

Final Talar Implant Positioning and Insertion

Select the appropriately sized Articular Surface Protector (Sizes 2-3 or 4-6) and insert it into the dovetail groove of the Tibial Implant with hole located anteriorly (**Figure 34**).

Hold the final Talar Implant with the Implant Holder and align it with the prepared talar peg holes.

Insert the Final Talar Implant by striking the end of the Talar Implant Impactor until complete contact is achieved between the Implant and the Talus (**Figure 35**).

Remove the Articular Surface Protector from the Tibial Implant using the Hockey Stick to engage the anterior hole.

Note: Take care to prevent damage or scratches to the Talar Implant's surface during implantation and impaction.

Final Insert Assembly

Align the final Tibial Insert with the anterior portion of the implanted Tibial Implant (**Figure 36A**). Initiate insert placement by manually sliding it into the Tibial Implant's grooves until contacting the dovetail locking feature (**Figure 36B**).

Assemble the Scroll Wheel to the Tibial Implant and Tibial Insert assembly and turn the Scroll Wheel clockwise to initiate final seating of the Insert (**Figures 36C & 36C+**).

Continue turning the Scroll Wheel clockwise until the Tibial Insert is fully engaged with the Tibial Implant and the Wheel is unable to advance any further (**Figures 36D & 36D+**).

Note: When pairing a Tibial Insert with a Tibial Implant that is one size larger (ex. Size 3 Tibia with Size 2 Talus and Insert), the final Insert location will be recessed relative to the anterior aspect of the Implant. Take care to confirm the Insert is fully engaged and locked in place.

Remove the Scroll Wheel by turning counterclockwise.

Note: Take care to prevent damage or scratches to the polished surface of the Talar Implant and the articular surface of the Tibial Insert during implantation.

Final Verification and Closure

Mobilize the ankle and confirm complete implant seating with fluoroscopic verification (**Figure 37**).

Close the surgical site per surgeon preference.



A

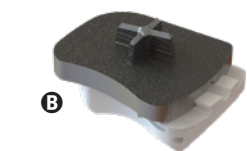

B

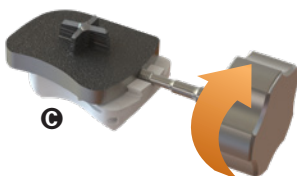

C

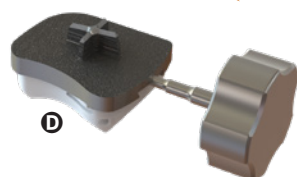

D

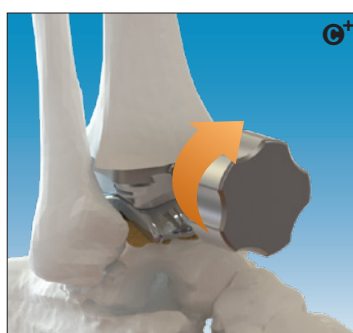

C+



D+

Figure 36. Tibial Insert Placement

A Tibial Implant and Insert

C Addition of Scroll Wheel (+ in-situ)

B Manual Assembly

D Final Seating of Insert (+ in-situ)



Figure 37. Final Standard Talus Construct

Flat-Cut Talar Technique with PSI

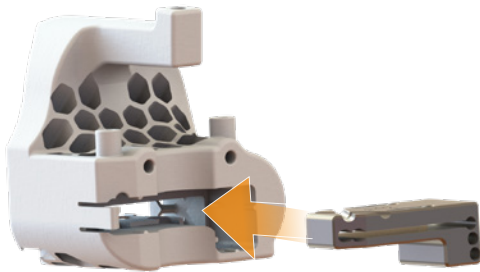

Figure 38. Tibial PSI and Resection Guide

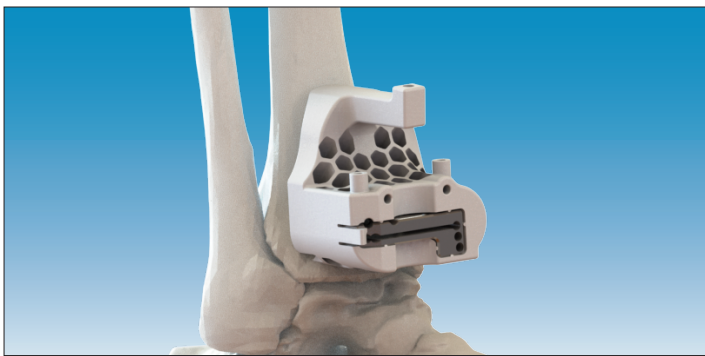

Figure 39. Placement of Tibial PSI Guide

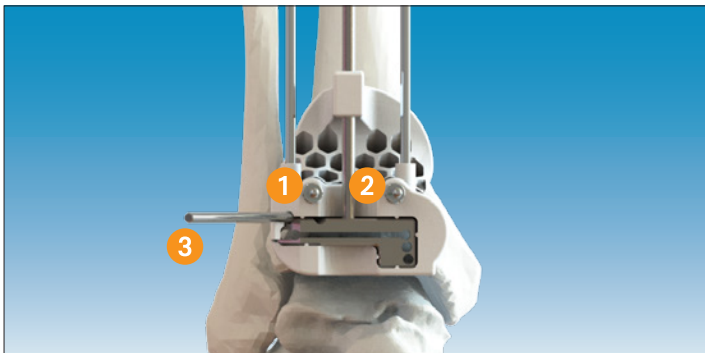

Figure 40. K-wire Fixation of Tibial PSI Guide

1. Initial Tibial Preparation

Assembly of Tibial Resection Guide to Tibial PSI Guide

Once the sterile field is established, select the appropriate Resection Guide for Tibial PSI from the instrument set, as indicated by the planning report and etching on the Tibial PSI Guide.

There are three Resection Guides for Tibial PSI which may be used for either left or right cases:

- A12 for size 2
- A34 for sizes 3 and 4
- A56 for sizes 5 and 6

Assemble the selected Resection Guide for Tibial PSI to the Tibial PSI Guide by sliding it into the dedicated slot on the anterior aspect of the guide (**Figure 38**).

Placement of the Tibial PSI Guide

Remove all remaining cartilage which may inhibit placement of the Tibial PSI Guide onto the anterior tibia.

Note: Any osteophytes identified during the planning process should remain intact in order to increase PSI stability. Refer to the associated planning report for clarification of these landmarks on a case-by-case basis.

Place the Tibial PSI Guide onto the tibia and seat it in the appropriate position on the patient's anatomy based on the surgical plan (**Figure 39**).

Full contact of the Tibial PSI Guide with the tibia must be observed before proceeding to the next step.

Tip: Placement of the Tibial PSI Guide onto the Tibial Bone Model may help to provide guidance for the appropriate tactile feedback upon proper seating to the bone.

Tibial PSI Guide Fixation

Once the Tibial PSI Guide is in position, use two parallel 2.5mm Olive Wires **1** **2** and a single oblique 2.5mm K-wire **3** to temporarily fix the guide to the tibia and prevent any backward movement during the cutting process (**Figure 40**).

Note: When inserting the Olive Wires or K-Wires through the Tibial PSI Guide, take care to apply constant pressure over the guide in order to maintain bone contact and avoid unintentional movement of the guide.

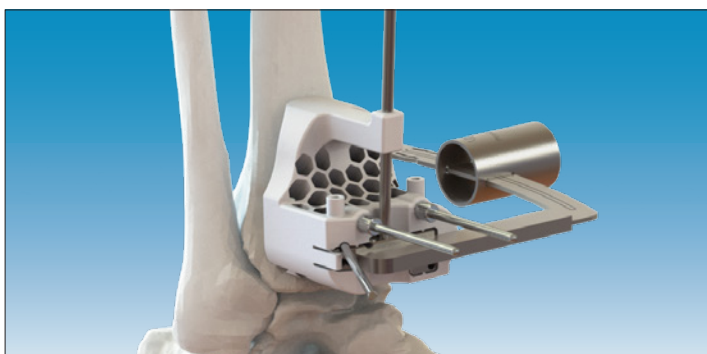

Figure 41. Assembly of Visualization Bow



Figure 42. Tibial Cut Trajectory and Nominal Resection

Insert the Tibial Axis through the central proximal hole of the Tibial PSI Guide and seat into the Resect Guide. Confirm proper positioning relative to the tibial mechanical axis using fluoroscopy. If necessary, remove the Olive Wires and K-wire to enable repositioning of the Tibial PSI Guide prior to moving to the next step.

! Note: The Tibial Axis must be fully seated into the Resection Guide to achieve stability and proper alignment with the Tibial PSI Guide.

Two vertical 2.5mm K-Wires may be placed into the superomedial and superolateral holes of the guide to confirm the mediolateral positioning of the Tibial PSI Guide.

Tibial Cut Visualization

Assemble the Control Cylinder for Flat-Cut onto the Visualization Bow by sliding the end of the bow through the slot on the side of the cylinder with the “Up” inscription oriented proximally.

! Note: The Visualization Bow may be positioned medially or laterally based on surgeon preference and accessibility. Take care to ensure proper orientation of the Control Cylinder before moving to the next step.

Insert the Visualization Bow into the cutting slot of the Resection Guide until fully seated against the anterior aspect of the guide (**Figure 41**).

Confirm placement with fluoroscopic verification.

The Visualization Bow corresponds with the cut trajectory achieved through the Tibial PSI Guide while the distance from the bow to the distal aspect of the Control Cylinder for Flat-Cut represents the 9mm nominal cut height.

! Tip: Take care to check for proper alignment of the fluoroscopy arm during this step by confirming that the cylinder is a perfect circle on the lateral view (**Figure 42**).

! Note: The 9mm nominal tibial resection can be modified during the planning process. If the tibial resection thickness was modified from nominal, the Control Cylinder may only be used as an alignment tool. The Visualization Bow will be used to verify the cut trajectory and tibial slope.

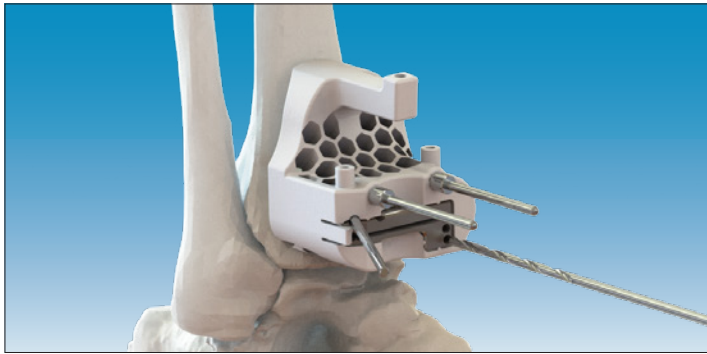

Figure 43. Tibial Stamping

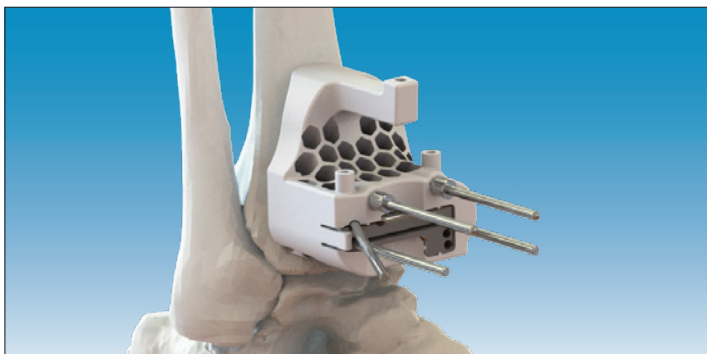

Figure 44. K-Wire Insertion

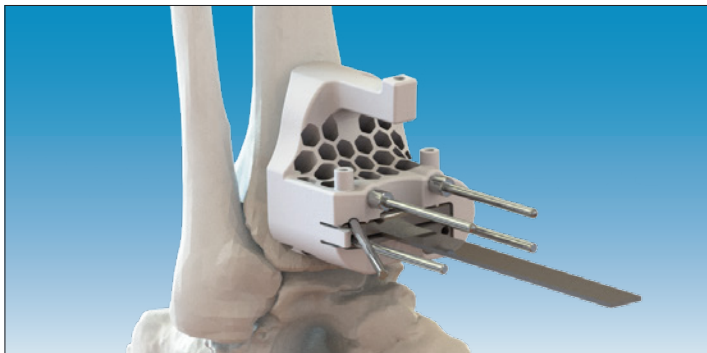

Figure 45. Tibial Resection

Tibial Stamping

The vertical tibial cut is created in a stamping fashion with the use of a 2.5mm drill.

Using a wire driver, insert and remove the 2.5mm drill through each hole in the Resection Guide, starting with the most distal and proceeding proximally in sequence (Figure 43).

Once the vertical tibial cut is completed, insert 2.5mm K-wires into the medial and lateral boundaries of the cutting slot of the Resection Guide (Figure 44).

! Note: There are two lateral holes located on each Resection Guide. The more lateral hole corresponds to the larger size (i.e. the more lateral hole on the A34 Guide is used when a Size 4 Tibial Implant was planned).

Horizontal Tibial Cut

Complete the horizontal tibial cut through the captured cutting slot in the Resection Guide (Figure 45).

! Note: Saw blades are not provided with the system. A narrow graduated saw blade that is 1.27mm thick, 13mm wide, and at least 80mm long is recommended for use.

! Tip: In order to avoid displacement of the Tibial PSI Guide, insert the sawblade into the center of the Resection Guide cutting slot and initiate the saw motion just prior to contacting the bone.

Remove the Olive Wires, K-Wires, and the Tibial PSI Guide once the tibial resection is complete.

If necessary, complete the tibial resection by hand. Use caution to follow the cut trajectory in order to maintain the planned orientation.

Remove the resected bone.

! Tip: The Corner Chisel may be used to aid in connection of the vertical and horizontal tibial resections for bone removal.

! Note: The talar dome will prevent full removal of the tibial bone resections at this point. Take care to remove the anterior half of the tibial resection to allow for seating of the Talar PSI Guide in the next step.



Figure 46. Standard Talar PSI and Resection Guide



Figure 47. Placement of Flat-Cut Talar PSI Guide

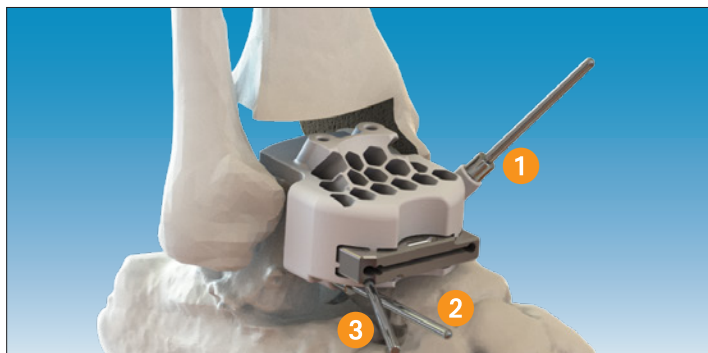

Figure 48. K-Wire Fixation of Flat-Cut Talar PSI Guide

2. Initial Talar Preparation

Assembly of Talar Resection Guide to Flat-Cut Talar PSI Guide

Following the planning report and etching on the Flat-Cut Talar PSI Guide, select the appropriate Resection Guide for Talar PSI from the instrument set.

There are three Resection Guides for Talar PSI which may be used for either left or right cases:

- B12 for size 2
- B34 for sizes 3 and 4
- B56 for sizes 5 and 6

Assemble the selected Resection Guide for Talar PSI to the Flat-Cut Talar PSI Guide by sliding it into the dedicated slot on the anterior aspect of the guide (**Figure 46**).

Positioning of the Flat-Cut Talar PSI Guide

Remove all remaining cartilage which may inhibit placement of the Talar PSI Guide onto the talus.

! **Note:** Any osteophytes identified during the planning process should remain intact in order to increase PSI stability. Refer to the associated planning report for clarification of these landmarks on a case-by-case basis.

Place the Flat-Cut Talar PSI Guide onto the talus and seat it in the appropriate position on the patient's anatomy based on the surgical plan (**Figure 47**).

Full contact of the Flat-Cut Talar PSI Guide with the talus must be observed before proceeding to the next step.

! **Tip:** Placement of the Flat-Cut Talar PSI Guide onto the Talar Bone Model may help to provide guidance for the appropriate tactile feedback upon proper seating to the bone.

Flat-Cut Talar PSI Guide Fixation

Once the Flat-Cut Talar PSI Guide is in position, insert two 2.5mm Olive Wires **1** **2** and a single oblique 2.5mm K-wire **3** to temporarily fix the guide to the talus and prevent any backward movement during the cutting process (**Figure 48**).

! **Note:** When inserting the Olive Wires or K-Wires through the Flat-Cut Talar PSI Guide, take care to apply constant pressure over the guide in order to maintain bone contact and avoid unintentional movement of the guide.

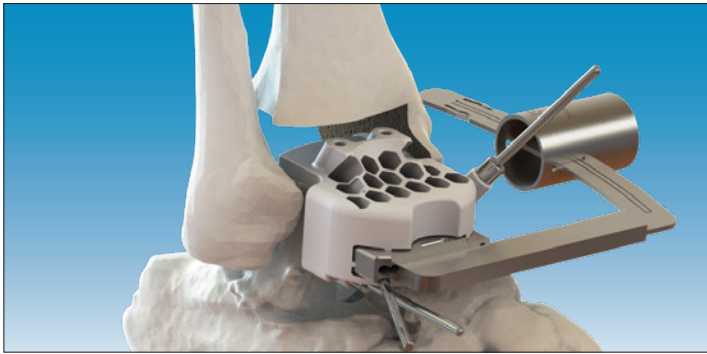

Figure 49. Assembly of Visualization Bow



Figure 50. Talar Cut Trajectory and Nominal Resection

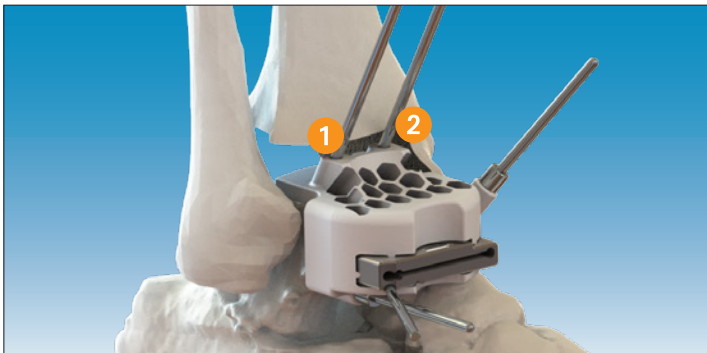

Figure 51. Marking of Talar Pegs



Figure 52. K-Wire Insertion

Talar Cut Visualization

Assemble the Control Cylinder for Flat-Cut onto the Visualization Bow by sliding the end of the bow through the slot on the side of the cylinder with the “Up” inscription oriented proximally.

! Note: The Visualization Bow may be positioned medially or laterally based on surgeon preference and accessibility. Take care to ensure proper orientation of the Control Cylinder before moving to the next step.

Insert the Visualization Bow into the cutting slot of the Resection Guide until fully seated against the anterior aspect of the guide (Figure 49).

Confirm placement with fluoroscopic verification.

The Visualization Bow corresponds with the cut trajectory achieved through the Flat-Cut Talar PSI Guide while the distance from the bow to the proximal aspect of the Control Cylinder for Flat-Cut Cut represents the 11mm nominal cut height.

! Tip: Take care to check for proper alignment of the fluoroscopy arm during this step by confirming that the cylinder is a perfect circle on the lateral view (Figure 50).

! Note: The 11mm nominal talar resection can be modified during the planning process. If the talar resection thickness was modified from nominal, the Control Cylinder may only be used as an alignment tool. The Visualization Bow will be used to verify the cut trajectory.

Marking of Talar Pegs

The two posterior-distally angled holes 1 2 on the proximal aspect of the Flat-Cut Talar PSI Guide are used to mark the locations of the talar pegs.

Mark the positions of both pegs by inserting a 2.5mm K-wire into each of the holes. Stop when the K-wire contacts cortical bone on the opposite side to avoid penetration of the subtalar joint (Figure 51). Remove both K-wires.

Horizontal Talar Cut

Insert 2.5mm K-wires into the medial and lateral boundaries of the cutting slot of the Resection Guide (Figure 52).

! Note: There are two lateral holes located on each Resection Guide. The more lateral hole corresponds to the larger size (i.e. the more lateral hole on the B34 Guide is used when a Size 4 Talar Implant was planned).



Figure 53. Talar Resection



Figure 54. Gap Check for Flat-Cut Talus



Figure 55. Tibial Recut Block

Complete the horizontal talar resection through the captured cutting slot in the Resection Guide (**Figure 53**).

Note: Saw blades are not provided with the system. A narrow graduated saw blade that is 1.27mm thick, 13mm wide, and at least 80mm long is recommended for use.

Tip: In order to avoid displacement of the Flat-Cut Talar PSI Guide, insert the sawblade into the center of the Resection Guide cutting slot and initiate the saw motion just prior to contacting the bone.

Remove the Olive Wires, K-Wires, and the Flat-Cut Talar PSI Guide once the talar resection is complete.

If necessary, complete the talar resection by hand. Use caution to follow the cut trajectory in order to maintain the planned orientation.

Remove the resected talar bone, and residual resected tibial bone, taking care to clear all debris from the area. The Hockey Stick may be used to access and remove any posterior bone fragments.

3. Resection Verification and Option Recut

Insert the Gap Sizer into the prepared joint with the laser marking reading "FC" facing the resected bone surface (**Figure 54**).

Note: The Gap Sizer is used for Standard and Flat-Cut operations. When the laser marking reading "FC" faces the resected bone surface, the minimum construct thickness with the Flat-Cut Talus is simulated.

If the Gap Sizer indicates that the existing resections will not accommodate the minimum construct thickness, the Resection Cut Adjustment Block shall be used.

Note: The Resection Cut Adjustment Block may be used for tibial and talar recuts, as indicated by the block's markings. Ensure the block is oriented correctly depending on the bone being addressed.

To recut the tibia, insert two 2.5mm K-wires into the holes created by the Olive Wires in the anterior tibia. Take care to orient the Resection Cut Adjustment Block so that the side marked "Tibia" is facing anteriorly and slide the block over the two K-wires at the desired recut height (**Figure 55**).



Figure 56. Optional Alignment with Flat-Cut Talar Template



Figure 57. Optional Peg Marking with Flat-Cut Talar Template



Figure 58. Placement of K-wires and Peg Preparation

Insert two 2.5mm K-wires into the medial and lateral cutting slot holes. Then, utilize the previously used saw blade to perform the cut.

Remove the K-wires and Resection Cut Adjustment Block once the recut is complete.

4. Final Talar Preparation

Optional Flat-Cut Talar Component Positioning

Should it be desired to modify the position of the talar component versus what was planned with the PSI, place the Flat-Cut Talar Template that corresponds to the planned implant size onto the resected talar surface. Initially orient the handle of the Template with the 2nd digit of the operative foot, then refine the rotation as needed to allow for alignment of the talar flanges with the handle (**Figure 56**).

Confirm placement with fluoroscopic verification, with a direct lateral view indicated by a perfect circle view of the thru-hole on the side of the Template.

Full contact between the Template and the talar resection should be obtained prior to moving to the next step.

Upon confirmation of appropriate alignment, fix the Flat-Cut Talar Template to the talus using two 2.5mm K-wires. Stop when the K-wires contact cortical bone on the distal side of the talus to avoid penetration of the subtalar joint (**Figure 57**).

Verify placement under fluoroscopy and remove the Template and K-wires.

Talar Pegs Preparation

Insert two 2.5mm K-wires into the holes created through the Talar PSI Guide or the Standard Talar Template.

⚠ Tip: Manual insertion of the K-wires is recommended to ensure proper alignment with the previously prepared holes.

Using the 5mm Flat-Cut Cannulated Peg Drill, drill over the K-wires until the Drill's step meets the bone (**Figure 58**).

Remove both K-wires.



Figure 59. Impaction of Flat-Cut Talar Trial

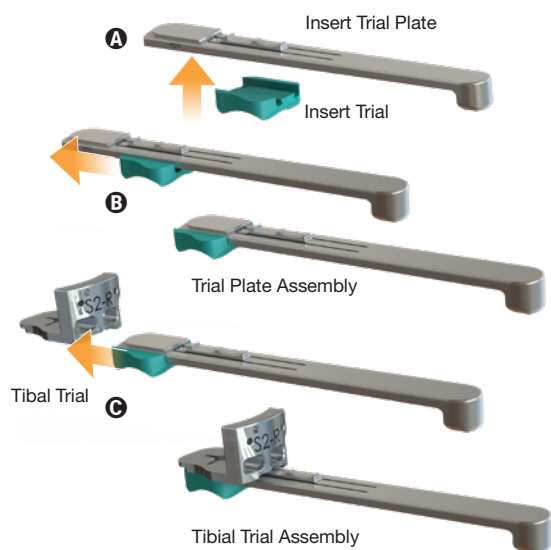

Figure 60. Tibial Trial Assembly

- A Insert Trial and Trial Plate
- B Assembly of Insert Trial and Trial Plate
- C Assembly of Tibial Trial to Trial Plate Sub-Assembly



Figure 61. Alignment of Tibial Trial Assembly



Figure 62. K-wire Fixation of Tibial Trial Assembly

5. Trialing

Flat-Cut Talar Trial Positioning

Following the planning report, select the appropriate Flat-Cut Talar Trial, Implant Holder, and Talar Implant Impactor from the instrument tray.

Align the Flat-Cut Talar Trial with the prepared talar peg holes and impact it into place with the Talar Implant Impactor (**Figure 59**).

Confirm placement with fluoroscopic verification.

Tibial Trial Assembly

Following the planning report, select the appropriate Insert Trial Plate and Insert Trial from the instrument tray. Take care to ensure size and side are correct (**Figure 60A**).

! *Note: The Insert Trial size must be the same size as the selected Talar Implant.*

Slide the Insert Trial Plate over the Insert Trial until the two components are clipped together (**Figure 60B**).

Select the appropriate Tibial Trial from the instrument set, taking care to ensure size and side are correct.

! *Note: The Tibial Implant size must be the same size or one size over the selected Talar Implant.*

Slide the Insert Trial Assembly into the Tibial Trial until the two components are clipped together (**Figure 60C**).

Tibial Trial Positioning

Insert the Tibial Trial Assembly into the prepared joint space and trial for fit and laxity. Mobilize the ankle to obtain desired positioning of the assembly over the Flat-Cut Talar Trial (**Figure 61**).

If increased construct height or reduced laxity is required, increase the Insert Trial thickness until the construct provides satisfactory results.

Fix the Tibial Trial Assembly to the tibia using two parallel and one oblique 2.5mm K-Wires (**Figure 62**).

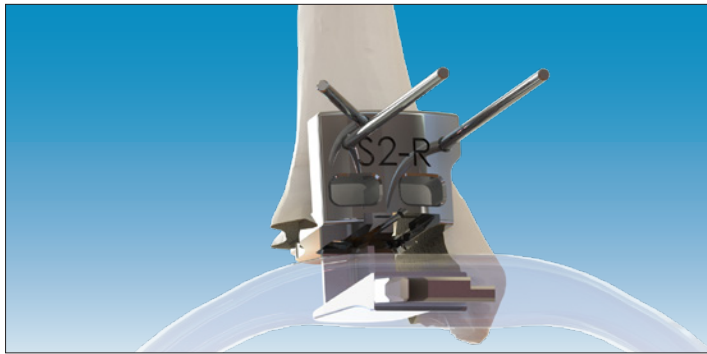

Figure 63. Alignment of Tibial Stem Shaper



Figure 64. Impaction of Tibial Stem Shaper

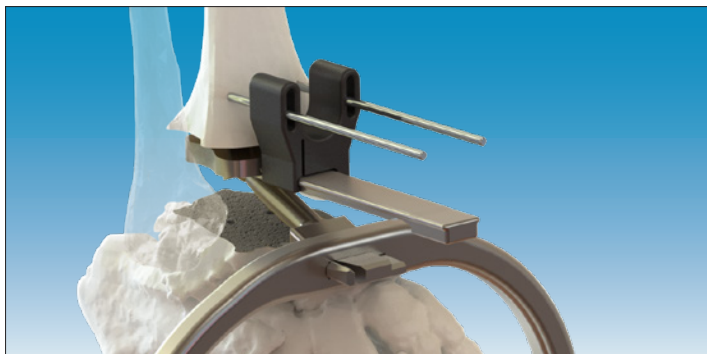

Figure 65. Assembly of Impaction Tip



Figure 66. Implanted Tibial Component

6. Tibial Stem Preparation

Remove the Insert Trial and Insert Trial Plate from the Tibial Trial Assembly, leaving the Tibial Trial implant in place on the tibia. Then remove the Standard Talar Trial from the talus.

Thread the Handle into the Impaction Frame until in full contact with the Frame. Then, assemble the Tibial Stem Shaper to the Impaction Frame. Slide the assembly into the prepared joint space while aligning the shaper with the Tibial Trial's cross-shaped socket (**Figure 63**).

Prepare the tibial stem by striking the Impaction Frame Hitting Plate with an axial force to drive the Tibial Stem Shaper into the tibia until complete contact with the Tibial Trial is obtained (**Figure 64**).

Remove the Impaction Frame and the Tibial Stem Shaper.

Remove the oblique K-wire from the tibia and slide the Tibial Trial out of the joint space while leaving the two parallel K-wires in place.

7. Implantation

Final Tibial Implant Insertion

Obtain the appropriate Final Tibial Implant and assemble it to the Tibial Implant Holder.

Assemble the Tibial Implant Guide to the Tibial Implant Holder. Verify the Tibial Implant Guide's correct orientation by referencing the side-specific laser markings on the Guide.

Slide the Tibial Implant Guide Assembly over the parallel K-wires until complete contact with the anterior wall of the tibia is achieved.

Assemble the Impactor Tip to the Impaction Frame. Then, slide the Impactor Tip into the groove on the Tibial Implant Holder until it is nested with the impaction socket on the handle (**Figure 65**).

Strike the Impaction Frame Hitting Plate with an axial force to insert the Tibial Implant into the tibia until fully seated.

⚠ Note: Take care to verify complete insertion of the Tibial Implant and full contact between the Tibial Tray and the tibia (**Figure 66**).



Figure 67. Inserted Articular Surface Protector



Figure 68. Flat-Cut Talar Implant Insertion

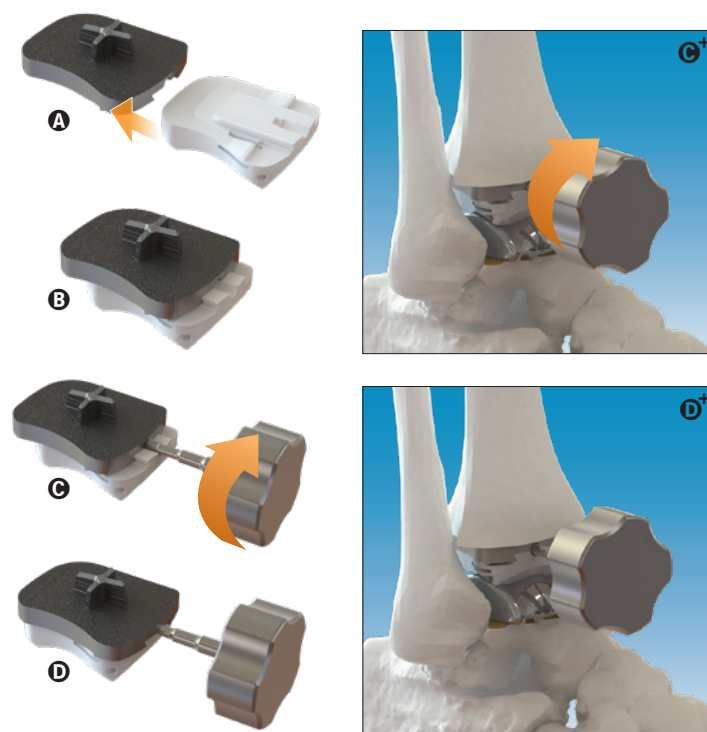

Figure 69. Tibial Insert Placement

- A** Tibial Implant and Insert
- B** Manual Assembly
- C** Addition of Scroll Wheel (+ in-situ)
- D** Final Seating of Insert (+ in-situ)

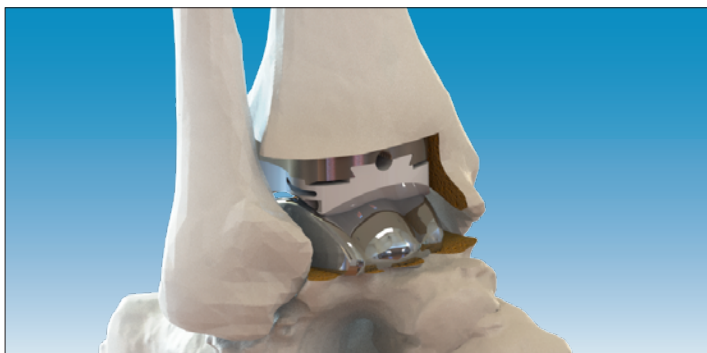

Figure 70. Final Flat-Cut Talus Construct

Remove all instrumentation and K-wires from the tibia while leaving the Tibial Implant in place.

Final Talar Implant Positioning and Insertion

Select the appropriately sized Articular Surface Protector (Sizes 2-3 or 4-6) and insert it into the dovetail groove of the Tibial Implant with hole located anteriorly (**Figure 67**).

Hold the final Talar Implant with the Implant Holder and align it with the prepared talar peg holes.

Insert the Final Talar Implant by striking the end of the Talar Implant Impactor until complete contact is achieved between the Implant and the Talus (**Figure 68**).

Remove the Articular Surface Protector from the Tibial Implant using the Hockey Stick to engage the anterior hole.

Note: Take care to prevent damage or scratches to the Talar Implant's surface during implantation and impaction.

Final Insert Assembly

Align the final Tibial Insert with the anterior portion of the implanted Tibial Implant (**Figure 69A**). Initiate insert placement by manually sliding it into the Tibial Implant's grooves until contacting the dovetail locking feature (**Figure 69B**).

Assemble the Scroll Wheel to the Tibial Implant and Tibial Insert assembly and turn the Scroll Wheel clockwise to initiate final seating of the Insert (**Figures 69C & 69C+**).

Continue turning the Scroll Wheel clockwise until the Tibial Insert is fully engaged with the Tibial Implant and the Wheel is unable to advance any further (**Figures 69D & 69D+**).

Note: When pairing a Tibial Insert with a Tibial Implant that is one size larger (ex. Size 3 Tibia with Size 2 Talus and Insert), the final Insert location will be recessed relative to the anterior aspect of the Implant. Take care to confirm the Insert is fully engaged and locked in place.

Remove the Scroll Wheel by turning counterclockwise.

Note: Take care to prevent damage or scratches to the polished surface of the Talar Implant and the articular surface of the Tibial Insert during implantation.

Final Verification and Closure

Mobilize the ankle and confirm complete implant seating with fluoroscopic verification (**Figure 70**).

Close the surgical site per surgeon preference.

Instrumentation

General Tray Contents

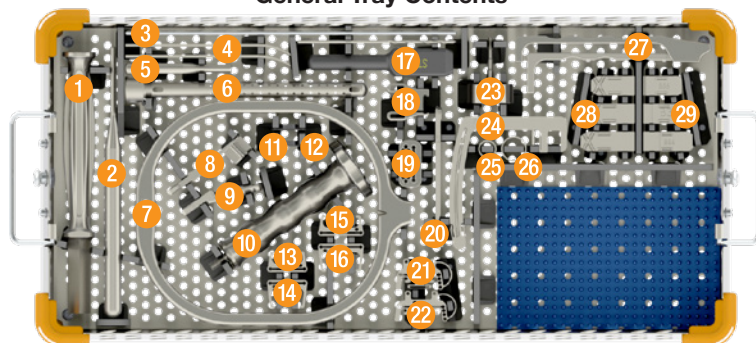

Side Specific Tray Contents

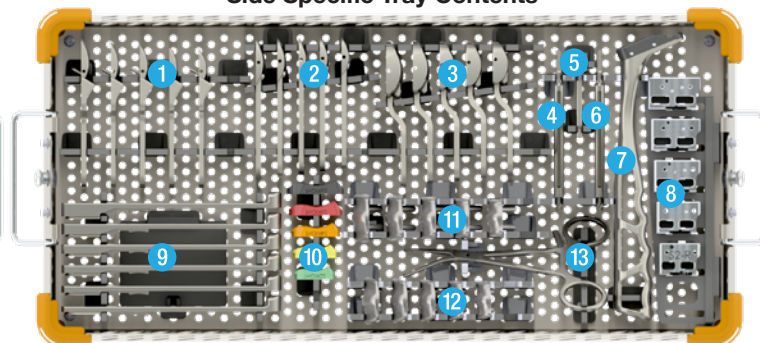

General Tray Contents

- 1 Corner Chisel.....M05 01241
- 2 Hockey StickM05 01251
- 3 Tibial AxisM05 00911
- 4 Insert Extractor (x2).....M05 01161
- 5 Pin Pusher.....M05 00971
- 6 K-Wire Storage Tube (x2).....G01 40021
- 7 Impaction Frame.....M05 00771
- 8 Tibial Stem ShaperM05 00801
- 9 Tibial Implant Impactor Tip.....M05 00761
- 10 Impaction Frame Handle.....M05 00791
- 11 Articular Surface Protector (Sizes 2-3).....M05 01301
- 12 Articular Surface Protector (Sizes 4-6).....M05 01311
- 13 Std Talar Resection Guide (Sizes 2-3).....M05 01191
- 14 Flat-Cut Talar Resection Guide (Sizes 2-3).....M05 01211
- 15 Std Talar Resection Guide (Sizes 4-6).....M05 01201
- 16 Flat-Cut Talar Resection Guide (Sizes 4-6).....M05 01221
- 17 Gap SizerM05 00961
- 18 Tibial Implant GuideM05 00731
- 19 Recut Block.....M05 00881
- 20 Tibial Implant Holder.....M05 00721
- 21 Reusable Resection Guide (Sizes 2-3).....M05 00951
- 22 Reusable Resection Guide (Sizes 4-6).....M05 01181
- 23 Scroll Wheel.....M05 00811
- 24 Visualization Bow.....M05 00891
- 26 Control Cylinder for Standard TalusM05 00901
- 25 Control Cylinder for Flat-Cut TalusM05 01171
- 27 Pin Puller*D11288M
- 28 Resection Guides for Tibial PSI
A12 – M05 00821, A34 – M05 00831, A56 – M05 00841
- 29 Resection Guides for Talar PSI
B12 – M05 00851, B34 – M05 00861, B56 – M05 00871

Side Specific Tray Contents

- 1 Talar Chamfer Resection Guides
Size 2 M05 00991 Size 5 M05 01021
Size 3 M05 01001 Size 6 M05 01031
Size 4 M05 01011
- 2 Standard Talar Templates
Size 2 M05 01051 Size 5 M05 01081
Size 3 M05 01061 Size 6 M05 01091
Size 4 M05 01071
- 3 Flat-Cut Talar Templates
Size 2 M05 01111 Size 5 M05 01141
Size 3 M05 01121 Size 6 M05 01151
Size 4 M05 01131

Side Specific Tray Contents Continued...

- 4 Cannulated Peg Drill (for Standard Talus).....M05 00661
- 5 Anterior Chamfer ReamerM05 00701
- 6 Cannulated Peg Drill (for Flat-Cut Talus).....M05 00671
- 7 Talar Implant ImpactorM05 00751
- 8 Tibial Trials
Right:
Size 2 M05 00022 **Left:**
Size 2 M05 00082
Size 3 M05 00032 Size 3 M05 00092
Size 4 M05 00042 Size 4 M05 00102
Size 5 M05 00052 Size 5 M05 00112
Size 6 M05 00062 Size 6 M05 00122
- 9 Insert Trial Plates
5mm M05 00251 8mm M05 00281
6mm M05 00261 9mm M05 00291
7mm M05 00271 11mm..... M05 01261
- 10 Insert Trials
Right:
Size 2 M05 00141 **Left:**
Size 2 M05 00201
Size 3 M05 00151 Size 3 M05 00211
Size 4 M05 00161 Size 4 M05 00221
Size 5 M05 00171 Size 5 M05 00231
Size 6 M05 00181 Size 6 M05 00241
- 11 Flat-Cut Talar Trials
Right:
Size 2 M05 00431 **Left:**
Size 2 M05 00491
Size 3 M05 00441 Size 3 M05 00501
Size 4 M05 00451 Size 4 M05 00511
Size 5 M05 00461 Size 5 M05 00521
Size 6 M05 00471 Size 6 M05 00531
- 12 Standard Talar Trials
Right:
Size 2 M05 00311 **Left:**
Size 2 M05 00371
Size 3 M05 00321 Size 3 M05 00381
Size 4 M05 00331 Size 4 M05 00391
Size 5 M05 00341 Size 5 M05 00401
Size 6 M05 00351 Size 6 M05 00411
- 13 Implant and Trial HolderM05 00741

Drills and K-Wires

- 2.5x70mm K-wire K10 NS257
- 2.5x100mm K-wire K10 NS251
- 2.5mm Tibial DrillM05 00711
- 2.5x100mm Olive Wire.....M05 01231

*Manufactured by: Oury Guye & Fils, 31 rue Malaingre, 52800 Nogent - France. +33 3 25 31 81 04

General Information

SYSTEM INTRODUCTION

The **QUANTUM® Total Ankle System** is a fixed-bearing semi-constrained ankle prosthesis comprised of two (2) components which are available in different sizes and configurations:

- A tibial component composed of a titanium (TA6V) metallic tibial tray implant fixed to a polymer (UHMWPE) insert
- A cobalt chrome (CoCr) metallic talar implant reproducing the talus dome anatomy.

Before surgery, the surgeon should utilize the provided implant sizing templates to identify the appropriate implant sizes for use during surgery.

Preoperative planning for the QUANTUM Total Ankle System is completed using three standard weight-bearing radiological views:

- Anterior view
- Anterior view with 30° internal rotation to expose the tibiofibular joint space
- Direct lateral view

Examination of the healthy side should be used for comparison.

Key planning elements defined from the anterior view:

- Implant size that does not impinge on the lateral malleolus
- Ideal joint line level that accounts for articular wear

Note: Comparative images are often necessary to assess the prosthetic joint line at the theoretical anatomic joint line. The thickness of the tibial resection is governed by this determination.

Key planning elements defined from the lateral view:

- Confirmation of implant size
- Evaluation of anterior osteophytic margin and assessment of the proposed bone resection necessary to expose the roof of the pilon
- Evaluation of the talar dome morphology, particularly the degree of convexity
- Evaluation of talar positioning, which may be centered or retroplaced beneath the pilon

Note: *The tibial component is always the same or one size larger than the talar component.*

Note: *The polyethylene insert is always the same size as the talar component.*

ORTHOPLANIFY™ PSI RESECTION GUIDE INTRODUCTION

QUANTUM PSI Guides for Total Ankle Replacement are comprised of the following components:

- One (1) patient-specific Tibial Guide for positioning of tibial instrumentation
- One (1) patient-specific Talar Guide for positioning of talar instrumentation
- One (1) patient-specific Tibial Bone Model, used as a preoperative visualization tool for the surgeon to reference his or her plan and the proper positioning of the Tibial Guide
- One (1) patient-specific Talar Bone Model, used as a preoperative visualization tool for the surgeon to reference his or her plan and the proper positioning of the Talar Guide

Note: *Prior to surgery, confirm that the ID Case of the QUANTUM PSI Guides and Bones Models correlate with the patient's information and the Quantum Total Ankle Replacement Implants.*



QUANTUM® PSI Guide Components

Indications / Contraindications

INDICATIONS:

The QUANTUM total ankle prosthesis is indicated as a total ankle replacement in primary or revision surgery for patients with ankle joints damaged by severe rheumatoid, post-traumatic, or degenerative arthritis.

Note: In the United States, the ankle prosthesis is intended for cement use only.

QUANTUM PSI GUIDES:

In2Bones QUANTUM Patient Specific Instrumentation (PSI) Guides for Total Ankle Replacement (TAR) is indicated as an orthopaedic instrument system to assist in the instrumentation positioning dedicated to In2Bones QUANTUM Total Ankle Replacement implantation. In2Bones QUANTUM PSI guides are compatible with QUANTUM tibial tray, QUANTUM tibial inlay, as well as standard and Flat-Cut QUANTUM talar implants. QUANTUM PSI Guides are intended for single use only. PSI Guides are manufactured in correlation with a pre-operative planning validated by the surgeon on the TAR Planning Software and assist in the positioning of the dedicated QUANTUM instrumentation with which drillings or bone cuts will be performed. In2Bones QUANTUM PSI guides are indicated for patient population fulfilling the QUANTUM Total Ankle Replacement indications and for which X-rays, and CT scan images are available and compliant with imaging protocol provided by In2Bones.

OrthoPlanify™ Planning Software:

The TAR Planning Software is a preoperative surgical planning software intended to be used with In2Bones QUANTUM Patient Specific Instrumentation (PSI) Guides and QUANTUM Total Ankle Replacement. TAR Planning Software allows the surgeon to use advanced display and positioning tools to guide the marking of bone before cutting and preview the total ankle replacement components intraoperatively, provided that anatomic landmarks necessary for alignment and positioning of the implant are identifiable on patient X-rays and imaging scans. X-rays and CT scan are the accepted imaging modalities for these procedures.

CONTRAINDICATIONS:

The QUANTUM Total Ankle Prosthesis is contraindicated for the following conditions:

- Sepsis, active / prior deep infection in ankle joint or adjacent bones, fever and/or local inflammation
- Avascular necrosis of the talus / tibia
- Osteoporosis / osteopenia
- Poor skin coverage / soft-tissue quality around the ankle joint that would make the procedure unjustifiable

- Inadequate or insufficient quality of bone stock, Important joint laxity or tendon dysfunction
- Neuromuscular or mental disorders which might jeopardize fixation and post-operative care
- Neurobiological diseases
- Non-functional lower limb muscle / weakness
- Skeletal immaturity
- Known allergy to one of the materials
- Pregnancy / breast-feeding woman

The QUANTUM PSI Guides should not be used if any of the following occur:

- The patient has an active infection
- Significant changes to patient's anatomy have occurred since the medical scan used for product definition was obtained
- The patient presents one of the contraindications for the QUANTUM Total Ankle Replacement implantation (refer to the QUANTUM TAR sterile implant instructions for use)

In2Bones® as the manufacturer of this device does not practice medicine. The surgeon who performs any implant procedure is responsible for determining and using the appropriate surgical techniques for implanting the device in each patient. This Surgical Technique Manual is furnished for information purposes, as an aid to properly use the device and its dedicated instruments.

Ordering Information

QUANTUM® Tibial Implants

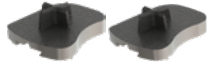

STANDARD		LONG	
PART NUMBER	DESCRIPTION	PART NUMBER	DESCRIPTION
M50 ST120	Tibial Implant, Standard, 2R	M50 ST121	Tibial Implant, Long, 2R
M50 ST130	Tibial Implant, Standard, 3R	M50 ST131	Tibial Implant, Long, 3R
M50 ST140	Tibial Implant, Standard, 4R	M50 ST141	Tibial Implant, Long, 4R
M50 ST150	Tibial Implant, Standard, 5R	M50 ST151	Tibial Implant, Long, 5R
M50 ST160	Tibial Implant, Standard, 6R	M50 ST161	Tibial Implant, Long, 6R
M50 ST220	Tibial Implant, Standard, 2L	M50 ST221	Tibial Implant, Long, 2L
M50 ST230	Tibial Implant, Standard, 3L	M50 ST231	Tibial Implant, Long, 3L
M50 ST240	Tibial Implant, Standard, 4L	M50 ST241	Tibial Implant, Long, 4L
M50 ST250	Tibial Implant, Standard, 5L	M50 ST251	Tibial Implant, Long, 5L
M50 ST260	Tibial Implant, Standard, 6L	M50 ST261	Tibial Implant, Long, 6L

QUANTUM® Talar Implants



STANDARD		FLAT-CUT	
PART NUMBER	DESCRIPTION	PART NUMBER	DESCRIPTION
M50 SC132	Talar Implant, Standard, 2R	M50 SC142	Talar Implant, Flat-Cut, 2R
M50 SC133	Talar Implant, Standard, 3R	M50 SC143	Talar Implant, Flat-Cut, 3R
M50 SC134	Talar Implant, Standard, 4R	M50 SC144	Talar Implant, Flat-Cut, 4R
M50 SC135	Talar Implant, Standard, 5R	M50 SC145	Talar Implant, Flat-Cut, 5R
M50 SC136	Talar Implant, Standard, 6R	M50 SC146	Talar Implant, Flat-Cut, 6R
M50 SC232	Talar Implant, Standard, 2L	M50 SC242	Talar Implant, Flat-Cut, 2L
M50 SC233	Talar Implant, Standard, 3L	M50 SC243	Talar Implant, Flat-Cut, 3L
M50 SC234	Talar Implant, Standard, 4L	M50 SC244	Talar Implant, Flat-Cut, 4L
M50 SC235	Talar Implant, Standard, 5L	M50 SC245	Talar Implant, Flat-Cut, 5L
M50 SC236	Talar Implant, Standard, 6L	M50 SC246	Talar Implant, Flat-Cut, 6L

QUANTUM® Tibial Fixed Inserts



SIZE 2		SIZE 3 Continued		SIZE 4 Continued		SIZE 5 Continued	
PART NUMBER	DESCRIPTION	PART NUMBER	DESCRIPTION	PART NUMBER	DESCRIPTION	PART NUMBER	DESCRIPTION
M50 SU125	Fixed Insert, 2R, 5mm	M50 SU139	Fixed Insert, 3R, 9mm	M50 SU245	Fixed Insert, 4L, 5mm	M50 SU259	Fixed Insert, 5L, 9mm
M50 SU126	Fixed Insert, 2R, 6mm	M50 SU131	Fixed Insert, 3R, 11mm	M50 SU246	Fixed Insert, 4L, 6mm	M50 SU251	Fixed Insert, 5L, 11mm
M50 SU127	Fixed Insert, 2R, 7mm	M50 SU132	Fixed Insert, 3R, 13mm	M50 SU247	Fixed Insert, 4L, 7mm	M50 SU252	Fixed Insert, 5L, 13mm
M50 SU128	Fixed Insert, 2R, 8mm	M50 SU133	Fixed Insert, 3R, 15mm	M50 SU248	Fixed Insert, 4L, 8mm	M50 SU253	Fixed Insert, 5L, 15mm
M50 SU129	Fixed Insert, 2R, 9mm	M50 SU235	Fixed Insert, 3L, 5mm	M50 SU249	Fixed Insert, 4L, 9mm		
M50 SU121	Fixed Insert, 2R, 11mm	M50 SU236	Fixed Insert, 3L, 6mm	M50 SU241	Fixed Insert, 4L, 11mm		
M50 SU122	Fixed Insert, 2R, 13mm	M50 SU237	Fixed Insert, 3L, 7mm	M50 SU242	Fixed Insert, 4L, 13mm		
M50 SU123	Fixed Insert, 2R, 15mm	M50 SU238	Fixed Insert, 3L, 8mm	M50 SU243	Fixed Insert, 4L, 15mm		
M50 SU225	Fixed Insert, 2L, 5mm	M50 SU239	Fixed Insert, 3L, 9mm				
M50 SU226	Fixed Insert, 2L, 6mm	M50 SU231	Fixed Insert, 3L, 11mm				
M50 SU227	Fixed Insert, 2L, 7mm	M50 SU232	Fixed Insert, 3L, 13mm				
M50 SU228	Fixed Insert, 2L, 8mm	M50 SU233	Fixed Insert, 3L, 15mm				
M50 SU229	Fixed Insert, 2L, 9mm						
M50 SU221	Fixed Insert, 2L, 11mm						
M50 SU222	Fixed Insert, 2L, 13mm						
M50 SU223	Fixed Insert, 2L, 15mm						
SIZE 3		SIZE 4		SIZE 5		SIZE 6	
PART NUMBER	DESCRIPTION	PART NUMBER	DESCRIPTION	PART NUMBER	DESCRIPTION	PART NUMBER	DESCRIPTION
M50 SU135	Fixed Insert, 3R, 5mm	M50 SU145	Fixed Insert, 4R, 5mm	M50 SU155	Fixed Insert, 5R, 5mm	M50 SU165	Fixed Insert, 6R, 5mm
M50 SU136	Fixed Insert, 3R, 6mm	M50 SU146	Fixed Insert, 4R, 6mm	M50 SU156	Fixed Insert, 5R, 6mm	M50 SU166	Fixed Insert, 6R, 6mm
M50 SU137	Fixed Insert, 3R, 7mm	M50 SU147	Fixed Insert, 4R, 7mm	M50 SU157	Fixed Insert, 5R, 7mm	M50 SU167	Fixed Insert, 6R, 7mm
M50 SU138	Fixed Insert, 3R, 8mm	M50 SU148	Fixed Insert, 4R, 8mm	M50 SU158	Fixed Insert, 5R, 8mm	M50 SU168	Fixed Insert, 6R, 8mm
		M50 SU149	Fixed Insert, 4R, 9mm	M50 SU159	Fixed Insert, 5R, 9mm	M50 SU169	Fixed Insert, 6R, 9mm
		M50 SU141	Fixed Insert, 4R, 11mm	M50 SU151	Fixed Insert, 5R, 11mm	M50 SU161	Fixed Insert, 6R, 11mm
		M50 SU142	Fixed Insert, 4R, 13mm	M50 SU152	Fixed Insert, 5R, 13mm	M50 SU162	Fixed Insert, 6R, 13mm
		M50 SU143	Fixed Insert, 4R, 15mm	M50 SU153	Fixed Insert, 5R, 15mm	M50 SU163	Fixed Insert, 6R, 15mm
				M50 SU255	Fixed Insert, 5L, 5mm	M50 SU265	Fixed Insert, 6L, 5mm
				M50 SU256	Fixed Insert, 5L, 6mm	M50 SU266	Fixed Insert, 6L, 6mm
				M50 SU257	Fixed Insert, 5L, 7mm	M50 SU267	Fixed Insert, 6L, 7mm
				M50 SU258	Fixed Insert, 5L, 8mm	M50 SU268	Fixed Insert, 6L, 8mm
						M50 SU269	Fixed Insert, 6L, 9mm
						M50 SU261	Fixed Insert, 6L, 11mm
						M50 SU262	Fixed Insert, 6L, 13mm
						M50 SU263	Fixed Insert, 6L, 15mm

REGULATORY INFORMATION

In2Bones, as the manufacturer of this device, does not practice medicine. The surgeon who performs any implant procedure is responsible for determining and using the appropriate surgical techniques for implanting the device in each patient. The Surgical Technique is furnished for information purposes, as an aid to properly use the device and its dedicated instruments.

RECOMMENDATION

It is recommended to carefully read the instructions for use available in the package insert.

DEVICES

- EC Classification (EC Directive MDD 93/42/EC):
- Implant: CE Class IIb – CE2797
- Instruments connected to a power driver: Class IIa – CE2797
- Trial implants: Class IIa – CE2797
- EC Regulation 2017/745/EC:
- Invasive reusable surgical instruments: Class Ir - CE2797
- Other instruments: Class I - CE

REIMBURSEMENT

Reimbursement may vary from countries to countries. Check with local authorities.

MANUFACTURER

In2Bones SAS
 28, chemin du Petit Bois
 69130 Ecully - FRANCE
 Tel: +33 (0)4 72 29 26 26
 Fax: +33 (0)4 72 29 26 29

All content contained herein is furnished for informational purposes only. In2Bones does not recommend a particular surgical product or procedure suitable for all patients. Each surgeon must evaluate the appropriateness of a device and corresponding techniques based on medical training, clinical judgment and surgical experience. The proper surgical technique and/or procedure are the responsibility of the medical professional. Indications, contraindications, warnings, and precautions are listed in the implant package insert and should be reviewed carefully by the physician and operating room personnel prior to any proposed procedure. Availability of these products might vary from a given country or region to another as a result of specific local regulatory approval or clearance requirements for sale in such country or region.

CAUTION: Federal law (USA) restricts this device to sale and use by, or on the order of a physician.



Corporate Headquarters

In2Bones Global, Inc. • Memphis, TN • USA
844. 602. 6637 • Info@i2b-USA.com

International Office

In2Bones SAS • Lyon • France
+33 (0)4 72 29 26 26

In2Bones.com

FOLLOW US...

